

MVE Doble Series

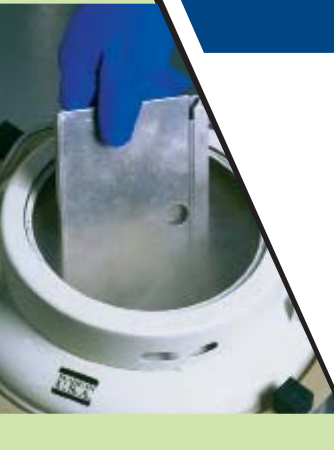

Features include

- MVE Protective Shipping Containers are recommended
- Protective shipping containers ensure upright shipping
- Liquid and vapor storage options
- Low liquid nitrogen consumption
- Convenient lightweight package
- **CHARGES IN TWO HOURS***



ADVANCED Charges in 2 hours
QWick Charge Technology
Pat. 20060099 Rev. C

Tank Features

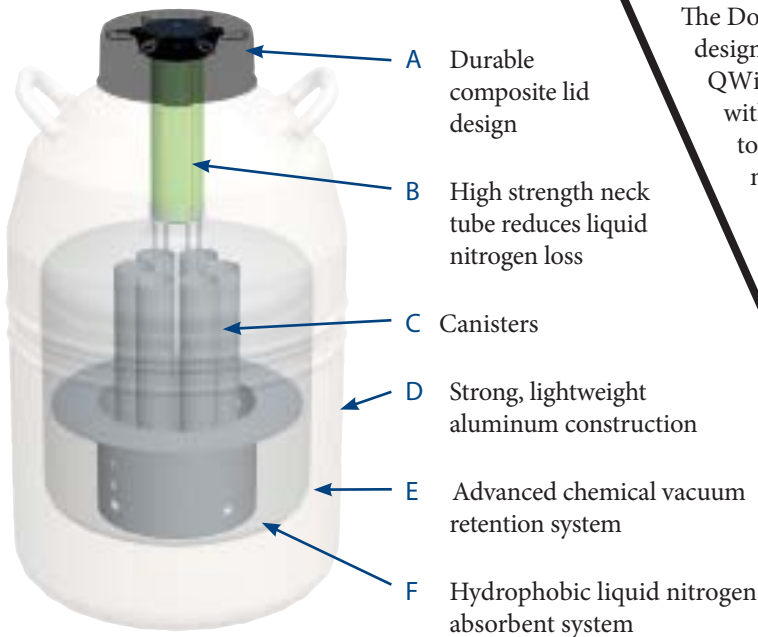

Featuring Advanced QWick™ Charge Technology

The Doble Series cryogenic liquid dewars are the first units to be designed for both vapor shipment and liquid storage. The Doble QWick Series utilizes an absorbent wicking material that charges with liquid nitrogen in two hours. *New/warm tanks still need to be filled with LN₂ and allowed to sit 24 hours to achieve maximum hold time. When a tank is already cold, the Advanced QWick Charge technology will apply, providing the capacity for same-day vapor shipping. A unique absorbent layer in the base of the storage tanks enables them to be charged with nitrogen and employed as dry shippers with hold times of up to 21 days. Once at the final destination, the tanks can be filled with liquid and used for long term storage, therefore avoiding the need for return shipments.

www.mvebio.com
 844-MVE-CRYO

	Doble 11	Doble 20	Doble 22	Doble 28	Doble 34	Doble 47	Doble 47-10
Maximum Storage Capacity							
Number of Canisters	6	6	6	6	6	6	10
No. of 1/2 cc Straws 10/cane	660	660	2400	2,400	2,100	4,500	3,500
Vial Capacity	210	210	810	810	630	1,320	1,050
Performance (Hold Time overrides NER specifications)							
LN ₂ Capacity w/o Inventory L est.	10.0	18.5	20.0	28.0	32.0	46.0	46.0
Vapor Capacity L	3.1	4.2	5.5	8.4	7.9	6.0	6.0
Static Evaporation Rate L/day	0.17	0.10	0.35	0.35	0.20	0.40	0.40
Working Duration days for liquid	37	116	40	50	110	74	72
Working Duration days for vapor	17	21	18	21	21	21	21
Unit Dimensions							
Neck Opening in (mm)	2.18 (55)	2.18 (55)	3.81 (97)	3.81 (97)	3.50 (89)	5.00 (127)	5.00 (127)
Overall Height in (mm)	21.6 (549)	25.5 (647)	22 (559)	22 (559)	26.6 (676)	26.5 (673)	26.5 (673)
Outside Diameter in (mm)	10.2 (260)	14.5 (368)	14.5 (368)	18.2 (462)	18.2 (462)	20.0 (508)	20.0 (508)
Canister Height in (mm)	11 (279)	11 (279)	11 (279)	11 (279)	11 (279)	11 (279)	11 (279)
Canister Diameter in (mm)	1.65 (42)	1.65 (42)	3.09 (79)	3.09 (79)	2.81 (72)	4.00 (101)	2.81 (72)
Weight Empty lb. (kg)	14.5 (6.6)	23 (10.4)	23.8 (10.7)	33 (15.0)	34.5 (15.6)	41 (18.5)	41 (18.5)
Weight Charged vapor lb. (kg)	19.5 (8.8)	30.3 (13.7)	35 (15.8)	47 (21.3)	47.9 (21.7)	54.6 (24.7)	54.6 (24.7)
Weight Full liquid lb. (kg)	32 (14.5)	56 (25.4)	68 (30.8)	89 (40.4)	92 (41.7)	117 (53.1)	117 (53.1)
Protective Shipping Container Part No.	20750519	11912460	11912460	11930861	20863878	14035731	14035731

TWO Year Parts Warranty • THREE Year Vacuum Warranty | Conforms to MDD 93/42/EEC, the Medical Device Directive for the EU.

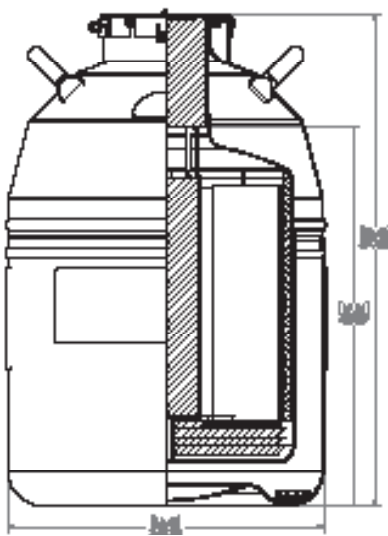

- FEATURES**
 LOCKABLE COCK AND COVER
 CHARGES IN 2 HOURS*
 OPTIONAL CENTER CANNISTER AND INLET TO EXTEND HOLD TIME
- PERFORMANCE**
 APPROX. LIQ. CAPACITY — 5.5 LITERS
 STATIC EVAPORATION RATE (EXCLUDING INVENTORY) — 0.35 L/DAY (EXCLUDING INVENTORY)
 STATIC HOLD TIME** (EXCLUDING INVENTORY) — 18 DAYS
- UNIT DIMENSIONS**
 NECK OPENING (mm) — 2.18 (55)
 OVERALL HEIGHT (TOP OF COCK) (mm) — 21.6 (549)
 OUTSIDE DIAMETER (mm) — 10.2 (260)
 EMPTY WEIGHT (kg) — 6.6 (14.5)
 CHARGED WEIGHT (EXCLUDING INVENTORY) (kg) — 8.8 (19.5)
 FULL WEIGHT (EXCLUDING INVENTORY) (kg) — 10.4 (23)
- CANNISTERS**
 QUANTITY: 6 — (6) 1175L200
 QUANTITY: 6 — (6) 1175L200
 QUANTITY: 10 — (10) 1175L200
- PLASTIC SHIPPING CONTAINER**
 PFC — PN 11912460
- NO FLAMING CURVED**



Visit www.mvebio.com for more information.

© 2020 MVE Biological Solutions reserves the right to discontinue its products, or change the prices, materials, equipment, quality, descriptions, specifications and/or processes to its products at any time without prior notice and with no further obligation or consequence. All rights not expressly stated herein are reserved by us, as applicable.